



# A Global Leader in Industrial Automation

Turck's sensors, connectivity, and fieldbus technology products are built to be the best. As one of the most **prominent** sensor manufacturers **in the world**, we even back our sensors with a **lifetime warranty**. Turck works by bringing **rugged engineering** solutions to your industrial automation applications.

**85,000+**  
SOLUTIONS

**50+**  
YEARS OF INNOVATION

**2,000+**  
EXPERIENCED SALES REPRESENTATIVES

Pioneer in non-contact  
**sensing** technology

Developed innovative **connectivity**  
solutions in response to our customers' needs

Recognized the need for advanced **I/O solutions**  
in harsh duty environments

**SUPPORT &  
DEDICATED SERVICE**

**EXTENSIVE WARRANTY**

 **4,000+**  
APPLICATION EXPERTS

RESPOND and SOLVE over **1,200** inquiries per day



Strategically placed manufacturing facilities in the

USA with **30** GLOBAL SUBSIDIARIES

**GLOBAL BUT LOCAL...**

**60** representations worldwide

# LS-5 Liquid Level Sensor

The LS-5 liquid level sensor is a probe-style level sensor that is inserted into a vessel for the purpose of measuring liquid level. The LS-5 liquid level sensor generates a low power electromagnetic pulse that is conducted down the probe. When this pulse contacts a liquid, a portion of that pulse is reflected back to the sensor. The time it takes for this pulse to be transmitted down the probe and reflected back is measured and then converted into a linear distance. This principle of operation is also commonly referred to as guided wave radar (GWR).



## Features

- Liquid level detection for both metallic and non-metallic vessels
- Output: 4-20 mA/ 0 - 10 V and switching PNP or NPN
- No moving parts
- Probes can be cut to length to ensure correct insertion depth
- IO-Link 1.1
- Sensing probe ignores deposits
- Suitable for small vessels and difficult vessel geometries
- Minimal programming setup required
- One sensor for both point and continuous level control
- Easy-to-use programming parameters to counter application factors that would render other level sensing technologies unsuitable
- Accessories available to accommodate non-metallic vessels and low dielectric constant fluids



## Easy to Use



### Versatile installation

LS-5 liquid level sensor probes can be cut to length, ensuring optimum insertion depth for every application.



### Point and continuous level control in one device

The LS-5 liquid level sensor allows for both point and continuous level control with one product.

# LS-5 Liquid Level Sensor

## LED display

The customizable LED display offers local indication of device conditions - units, percentage of fill and analog output.

## Programming pushbuttons

Pushbuttons allow local programming on the device as an alternative to IO-Link.

## Rotatable housing

Sensor body can be rotated up to 340° after installation to ensure ideal viewing angle for an operator.

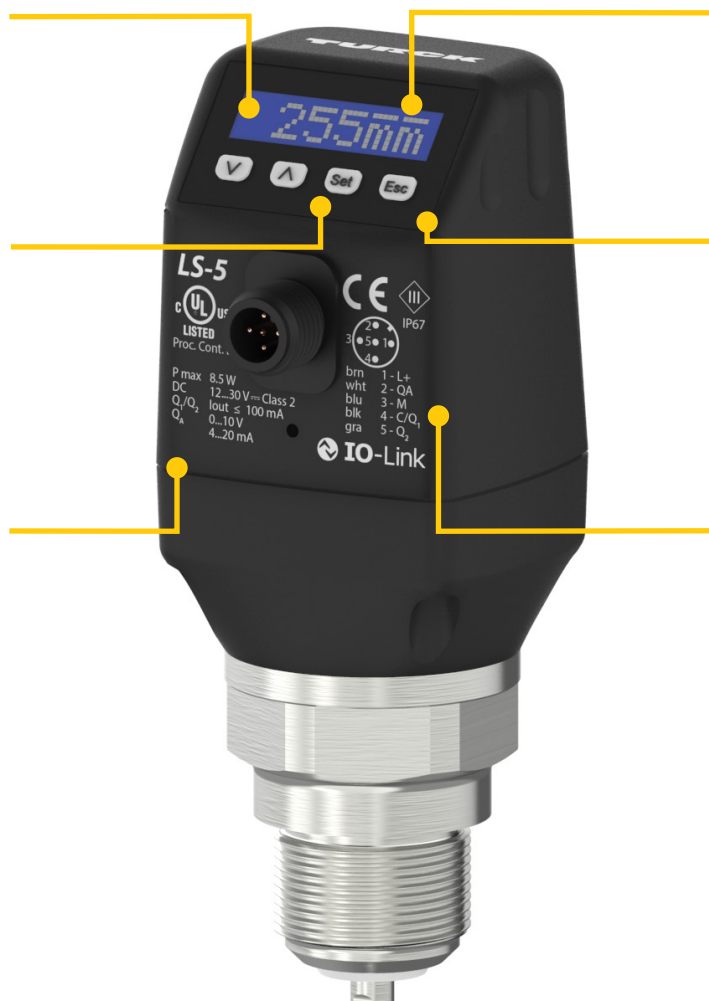

## Switch point LEDs

Two LEDs indicate the state of the switching outputs.

## Sloped display

The 45° display angle of the user interface offers increased visibility from multiple viewing angles.

## Local wiring diagram

Wiring diagram details pin assignment on the electrical connector.



## Easy to Apply



### Plug and play

With minimal programming involved, most applications are up and running as soon as the output behavior is defined - further simplified by auto-detecting 4-20 mA or 0-10 VDC analog output.



### IO-Link 1.1

IO-Link process data and programming available on all models.

# LS-5 Liquid Level Sensor



## Performance Data

Measurement Accuracy	± 5 mm
Temperature Drift	≤ 0.1 mm
Hysteresis	≥ 2 mm
Repeatability	≤ 2 mm
Inactive Area at Process Connection (IA)	25 mm
Inactive Area at Probe End (IAE)	10 mm
Dielectric Constant	≥ 5 Mono-probe only ≥ 1.8 with coaxial tube accessory***
Pressure Resistance	-1 to 10 bar
Maximum Force Applied to Probe	6 Nm

\*\*\* Coaxial tubes are only available for LS-551 level sensors with G3/4 process connection

## Electrical Data

Operating Voltage	12 - 30 VDC
Current Consumption	≤ 100 mA
Programmable Analog Output	4 - 20 mA / 0 - 10 VDC
Analog Load Current	≤ 0.5 kΩ,
Analog Load Voltage	≥ 0.75 kΩ
Response Time	< 400 ms, typ
Short Circuit/ Reverse Polarity Protection	Yes/Yes
IO-Link	Version 1.1

## Environmental Data

Ambient Temperature	-20 to 60 °C
Storage Temperature	-40 to 80 °C
Media Temperature	-20 to 100 °C
Housing Materials	Plastic, PBT
Wetted Materials	Stainless Steel, 1.4404, (316L) PTFE, FKM
Wetted Materials - Coaxial Tube	Stainless Steel, 1.4571, (316Ti)

# Part Number Key

LS - 5 51 - 0200 - LIU22PN8 X - H1151

## Functional Principle

LS = Level sensor

## Design

5 = Sensor head rotatable 340°

## Process Connection

51 = G3/4

34 = NPT 3/4 (cannot be combined with coaxial tube)

## Insertion Length

0000 = Without probe

0200 = 200 mm

0300 = 300 mm

0400 = 400 mm

0500 = 500 mm

0600 = 600 mm

0700 = 700 mm

1000 = 1000 mm

## Electrical Connection

H1151 = M12 x 1, 5 contacts

H1181 = M12 x 1, 8 contacts

## Output Function

LIU22PN8X = 4 mA...20 mA/0 V...+10 V,

IO-Link v1.1, 1x PNP + 1 x PNP/NPN

LIU24PN8X = 4 mA...20 mA/0 V...+10 V,

IO-Link v1.1, 1x PNP + 3 x PNP/NPN

## Dimension Drawings

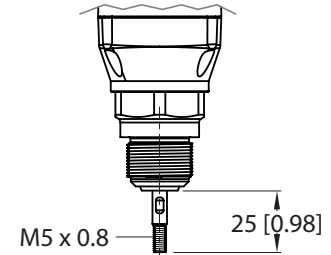
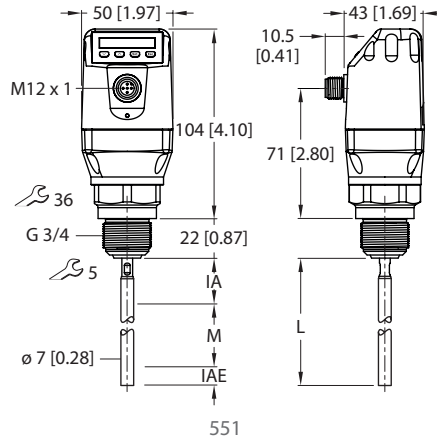
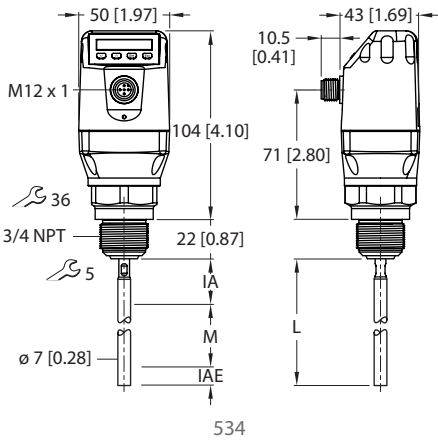

Sensor Head Detail

## Pinouts

LIU22PN8

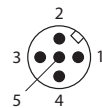

Recommended Cordset: RK 4.5T-\*/S618

LIU24PN8

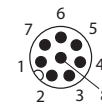

Recommended Cordset: RKC 8T-\*/S618

## Wiring Diagram

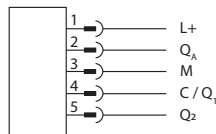

LIU22PN8

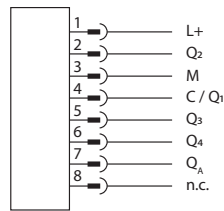

LIU24PN8

## Wiring Diagram Key

- L+ = Supply voltage
- Q<sub>a</sub> = Analog current/voltage output
- M = Supply common/analog common
- C/Q<sub>1</sub> = Switching output 1, PNP/IO-Link communication
- Q<sub>2</sub> = Switching output 2, PNP/NPN
- Q<sub>3</sub> = Switching output 3, PNP/NPN
- Q<sub>4</sub> = Switching output 4, PNP/NPN
- n.c. = No function

# Accessory Part Number Key

**Coaxial Tubes** (for use with non-metallic vessels and/or low dielectric liquids)

Dimension Drawing

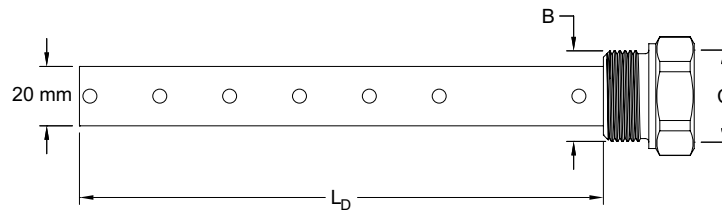

Coaxial Tube

Description	Material Number	Dimension C	Dimension B	Insertion Length (mm)	L <sub>d</sub> (mm)
LSCT-51-0200	100001872	G3/4	G3/4	200	184
LSCT-34-0200	100001873	G3/4	NPT 3/4	200	184
LSCT-51-0300	100001874	G3/4	G3/4	300	284
LSCT-34-0300	100001875	G3/4	NPT 3/4	300	284
LSCT-51-0400	100001876	G3/4	G3/4	400	384
LSCT-34-0400	100001877	G3/4	NPT 3/4	400	384
LSCT-51-0500	100001878	G3/4	G3/4	500	484
LSCT-34-0500	100001879	G3/4	NPT 3/4	500	484
LSCT-51-0600	100001880	G3/4	G3/4	600	584
LSCT-34-0600	100001881	G3/4	NPT 3/4	600	584
LSCT-51-0700	100001882	G3/4	G3/4	700	684
LSCT-34-0700	100001883	G3/4	NPT 3/4	700	684
LSCT-51-1000	100015813	G3/4	G3/4	1000	984
LSCT-34-1000	100015818	G3/4	NPT 3/4	1000	984
LSCT-51-1500	100015814	G3/4	G3/4	1500	1484
LSCT-34-1500	100015817	G3/4	NPT 3/4	1500	1484
LSCT-51-2000	100015815	G3/4	G3/4	2000	1984
LSCT-34-2000	100015816	G3/4	NPT 3/4	2000	1984

## Replacement Probes

Dimension Drawing

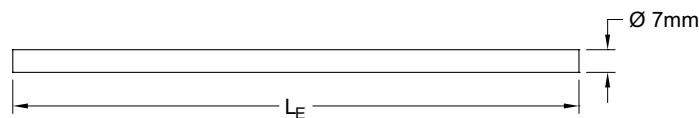

Replacement Probe

Description	Material Number	Insertion Length (mm)	L <sub>e</sub> (mm)
LSRP-0500	100002196	500	490
LSRP-1000	100002197	1000	990
LSRP-1500	100015812	1500	1490
LSRP-2000	100015371	2000	1990

# Turck Level Sensing Technology

## Level Considerations

Liquid level applications can be broken down into continuous sensing and point monitoring.

Continuous level sensing provides a constant verification of the contained liquid, usually via an analog signal. Point level sensing is used for a specific level position, such as an empty tank, full tank or overflow alarm point, commonly achieved by discrete switching outputs.

For many applications, accurately gauging level in a container has more implications and poses more risk than merely reporting a container's empty/full conditions. Media that has the potential to "run dry" can cause catastrophic damage to other areas in the process. Additionally, messy overfills are not just pain-staking to clean, but may pose risks depending on where it's located (hazardous materials and locations).

In order to select the best method of measuring or sensing liquid level, many factors need to be considered. The properties of the liquid, the materials of the container and environmental considerations can all have an impact on the chosen level sensor technology.

Turck offers a variety of level sensing options that allow users to select the optimal sensor for each application. For example, our pressure sensors can reliably sense the hydrostatic head pressure of a liquid. For a non-intrusive option, Turck offers capacitive technology, which is perfect for sight glasses or plastic containers that store media with a higher dielectric constant. For non-viscous media, magnetostrictive float technology is ideal. In addition, if your application has density changes then ultrasonic level sensing technology is a great option.

## LS-5 Liquid Level Sensor

For difficult sensing conditions, the LS-5 Guided Wave Radar sensing system may be the most reliable choice as it operates independently of many changing process conditions. GWR offers measurement readings that are independent of the chemical or physical properties of the process media with which it is in contact.

### Applications include:

- Accumulators
- Chemical storage and small additive vessels
- Lube oil pots and reservoirs
- Balance tanks used to maintain a constant level of product above a pump inlet
- Level in hydraulic power units
- Machine tool cutting fluids

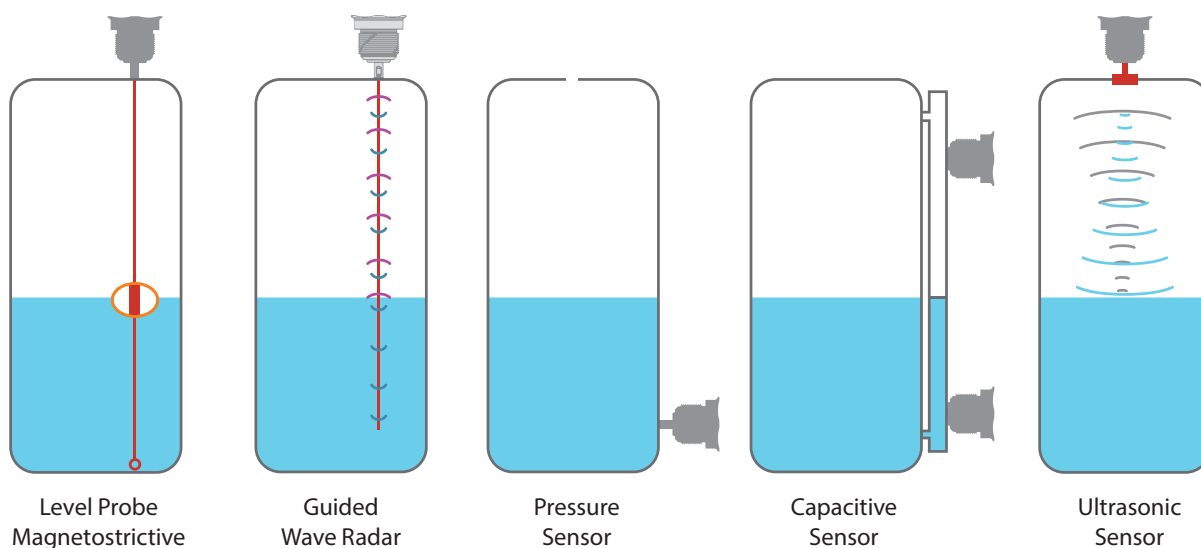



# Application Considerations

- The LS-5 liquid level sensor can be used in metal containers or bypass/immersion pipes. A coaxial tube is required for use in non-metallic tanks.
- Water-based liquids have a Dielectric Constant (DK) value of  $> 5$ , which makes for a very "attractive" target.
- For liquids with a DK value of  $< 5$ , the use of a coaxial tube is recommended.
- Static interference signals in the tank generated by tubes, beams, couplings, or cleaning balls can be taught in.
- When using the LS-5 liquid level sensor with a coaxial tube, there are no minimum distances from sources of interference that need to be observed.
- When using the LS-5 liquid level sensor with the mono-probe only, the minimum distances in the below diagram must be observed.

## Installation in a container

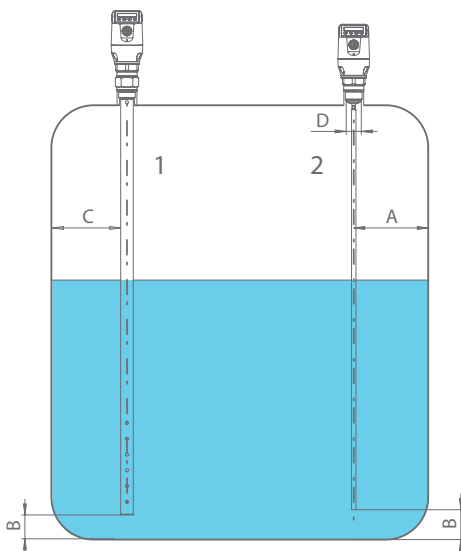

### 1. Coaxial tube in metallic and non-metallic containers

C= In the case of a coaxial probe there are no minimum distances from the container wall and built-in components to be observed.  
 $B \geq 10 \text{ mm}$

### 2. Mono-probe with metallic containers

Installation in the nozzle:  
 $D \geq \text{DN } 25$

Distance to container wall/container bottom:  
 $A \geq 50 \text{ mm}$   
 $B \geq 10 \text{ mm}$

Distance to components built into the container:  
 $\geq 100 \text{ mm}$

## Installation in a metal immersion tube or metal bypass

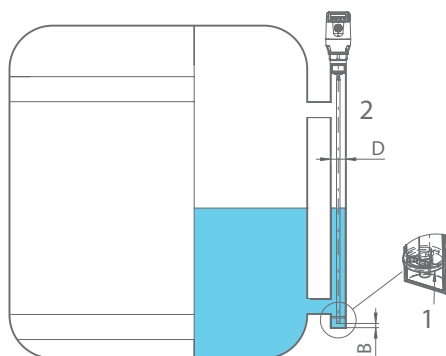

### 1. Centering

### 2. $D \geq \text{DN } 25$

Distance to bypass/container bottom:  
 $B \geq 100 \text{ mm}$

**Centering:** To prevent contact between the probe and the bypass pipe during oscillations, the probe should be centered according to its length and depending on the diameter of the bypass pipe. To do this, it is necessary to insert one or two centering pieces.

# Typical Applications

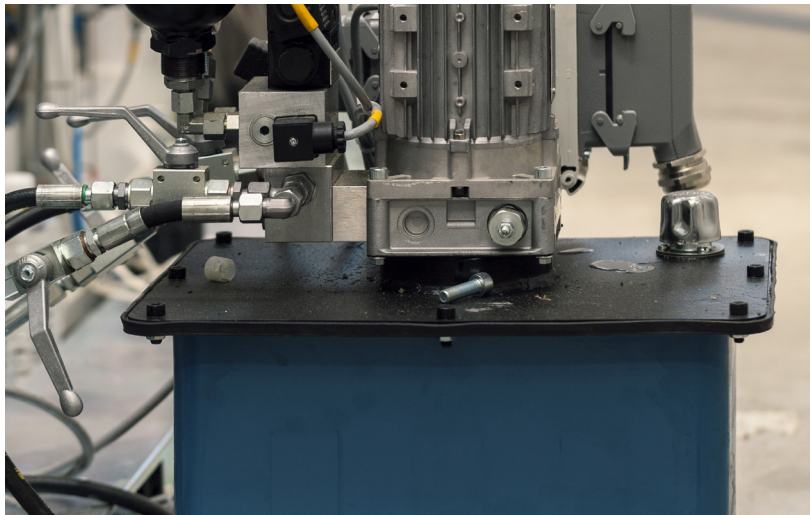

## Controlling hydraulic level

In demanding hydraulic applications, leaks and hose ruptures are common. The low oil levels that result from these failures can cause performance problems in downstream equipment that can result in downtime and quality problems. Extreme cases of low oil level can lead to pump failure, which will always result in costly downtime. The LS-5 sensor with an optional coaxial tube acts as a stilling well to minimize the influence of internal turbulence.



## Monitoring the level of coolant

Machining operations rely on coolant to maintain the quality of the finished parts. The coolant also protects the cutting tools from wear and damage caused by excessive heat build-up. For these reasons, it is important to ensure the cooling lubricant level is properly monitored. The LS-5 liquid level sensor reliably monitors the level of these coolants even in the presence of foam and contaminants. The sensor provides high and low level alarms as well as analog level for advanced monitoring.



## Monitoring detergent level

Automated washing systems are used in many industries to remove undesirable contaminants from products. At the heart of these systems is often a water-based solution containing cleaning detergent. Maintaining liquid level in these systems not only ensures the parts are being cleaned but also protects the equipment. Low liquid level can create cavitation within the pumps, resulting in low pressure from the spray nozzles. With its ability to ignore foam in addition to corrosion resistant wetted materials, the LS-5 liquid level sensor provides an easy-to-apply solution in these applications.

Turck Inc. sells its products through Authorized Distributors. These distributors provide our customers with technical support, service, and local stock. Turck distributors are located nationwide – including all major metropolitan market areas.

For Application Assistance or for the location of your nearest Turck distributor, call:

1-800-544-7769

Specifications in this manual are subject to change without notice. Turck also reserves the right to make modifications and makes no guarantee of the accuracy of the information contained herein.

Literature and Media questions or concerns?  
Contact Turck USA Marketing – [tusa.marketing@turck.com](mailto:tusa.marketing@turck.com)

# TURCK

Ramco Innovations  
1207 Maple St  
PO Box 65310  
West Des Moines IA, 50265

Phone: (515) 225-6933  
Toll Free: (800) 328-6236  
Or: (800) 280-6933  
Fax: (515) 225-0063

Ramco Innovations  
5900 N. 58th Street  
Suite 2  
Lincoln, NE 68507

Phone: (402) 467-4041  
Toll Free: (888) 304-7629  
Fax: (402) 467-4072

30 subsidiaries and over  
60 representations worldwide!

Printed in USA

B1057 B 03/20

©2020 by Turck Inc. All rights reserved. No part of the  
publication may be reproduced without written permission.

[www.turck.com](http://www.turck.com)